

HFT Pipestoppers® Nylon Plugs

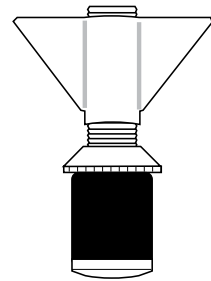

HFT PIPESTOPPERS®



HFT Pipestoppers® **Nylon Pipe Plugs** are suitable for a myriad of applications. They are mostly used for weld testing, leak testing of pipework fabrications, weld purging or simply stopping to prevent the ingress of dirt, rodents and other unwanted material. However there are over 100 different applications for these plugs.

These plugs are constructed from injection moulded nylon components and rubber rings. They have the advantages of being light, non rusting easy to expand and can be dismantled for cleaning purposes.

The grade of nylon chosen is pure nylon 6 which has considerable wear characteristics and makes them stronger and more robust than other plastic plugs.

These plugs will provide airtight seals and in tests with plastic pipes they are capable of sealing against pressures from 60 Psi - 4 bar, to over 100 Psi - 7 bar.

Effective sealing is simple, insert the plug into a pipe opening and tighten the wing nut clockwise. The rubber ring will expand and provide a positive seal. To remove simply reverse the process.

APPLICATIONS

They are in normal usage for plumbing operations in a wide variety of industries, including domestic and industrial water and drainage systems.

Also for ducting and conduit, plastic pipe bending, swimming pools, masking in painting and casting industries and many others.

SOLID SHAFT PLUGS

Sizes available are for pipe bore sizes

Nominal	I.D. Range	Psi	Bar
½"	12 - 16 mm	100-150*	7-10*
¾"	18 - 24 mm	150*	10*
1"	23 - 32 mm	130*	9*
1¼"	31 - 42 mm	70*	5*
1½"	37 - 54 mm	60*	4*

HOLLOW SHAFT PLUGS

With 10mm BSP threaded waterway:

Nominal	I.D. Range	Psi	Bar
½"	12 - 16 mm	100-150*	7-10*
¾"	18 - 24 mm	150*	10*
1"	23 - 32 mm	130*	9*
1¼"	31 - 42 mm	70*	5*
1½"	37 - 54 mm	60*	4*

With ½" BSP threaded waterway:

Nominal	I.D. Range	Psi	Bar
2"	48 - 65 mm	18 - 50*	1.2 -3.4*
2 ½"	60 - 77 mm	34.5*	2.3*
3"	70 - 87 mm	15*	1.0*
3.5"	83 - 97 mm	-	-
4"	95 - 110 mm	15*	1.0*
4.5"	114 - 130 mm	-	-
5"	121 - 142 mm	12*	0.8*
6"	148 - 162 mm	10*	0.6*

*= results depend upon exact ID of the tube/pipe, number of turns, condition of the inside of the pipe and the material.
* Pressure tests were carried out at 18°C (64.4°F). As working temperature is increased, it can be expected that pressure ratings must be reduced.

HFT PIPESTOPPERS®

TECHNICAL INFORMATION

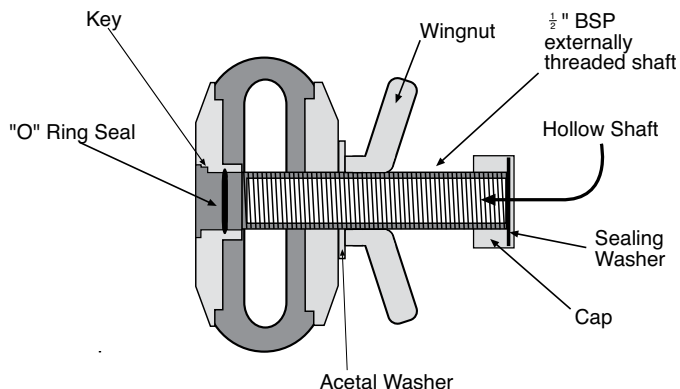

As can be seen from the sectioned view, the unique assembly of the central waterway into the base plate via a snap taper fit and "O" ring seal provides a positive water and air tight joint. The provision of a friction reducing acetal copolymer thrust washer inserted between the wing nut and top plate facilitates easy expansion and release.

Sizes available are for pipe bore sizes.

These plugs conform to ISO Standards for low pressure testing and sealing of pipes.

NOTES:

- They are slightly less efficient at the extreme higher limits of expansion than in the middle and lower ranges
- Pressure testing depends upon the cleanliness and condition of the pipe bore
- Nitrile, silicone and viton rubber seals to resist different chemicals and higher temperatures are available from stock as accessories
- Operators using air or other gases to make leak tests must take the appropriate precautions



ALUMINIUM EXPANDING PLUGS

To complete the HFT Pipestoppers® range of **Nylon Expanding Plugs** we offer all sizes of **Aluminium Plugs**.

These are provided in sizes from 3" (76 mm), for more arduous duties such as long immersion in water and higher temperature and are manufactured with ½", 1", 2" (13 mm, 25 mm, 51 mm) outlets.

The standard seals are made from natural rubber and special rubber seals are available for chemical applications where greater resistance is required.



INFLATABLE STOPPERS

Available as **Cylindrical, Spherical** or **Special Stoppers** for use when breaking into existing lines for repairs, maintenance and new sections.

These are especially useful where entrance and exit apertures are difficult to access with solid plugs.

Each stopper is available in 1" (25 mm) sizes from 2" (51 mm) up to 82" (2083 mm) as standard and larger to special order.



HFT PIPESTOPPERS®

Product Range of HFT Pipestoppers® Division:

Pipestoppers® Expandable Nylon Pipe Plugs
 Pipestoppers® Weld Purge Plugs™ & Orbital Welding Purge Plug Kits
 Pipestoppers® Expandable Aluminium Plugs
 Pipestoppers® Expandable Steel Plugs
 Pipestoppers® Spherical, Cylindrical and PetroChem™ Inflatable Stoppers
 Pipestoppers® Inflatable Low Profile Stoppers and Rubber Plugs
 Pipestoppers® Accu-Freeze™ & Qwik-Freezer™ ice plug makers

Our HFT® Weld Purging Products

Argweld® PurgEye® Weld Purge Monitors®, Argweld® Inflatable Tube, Pipe & Pipeline Weld Purging Systems, Argweld® Weld Purge Accessories, Techweld® MultiStrike® Tungsten Electrodes